

# Flower Freshness Management

We provide solutions to help maintain the freshness of flowers and enhance their quality.



## Flower Freshness Management

### Flower Freshness Management in the production process

- Use of water absorption enhancers and cut flower nutrients in pre-treatment of bouquets
- Quick work with bouquet processors

### Flower Freshness Management in Distribution

- Flower Delivery Bucket
- Use of Preservatives and Cut Flower Nutrients

### Flower Freshness Management in Sales process

- Cut flower nutrients are included in the pocket of the flower bag.

## SLEEVE MEDIA

We see limitless potential in a flower sleeve. What was once just a protective sleeve for flowers is now evolving into a promotional tool and a platform for information sharing, with its functionality and value steadily increasing. We envision a future where more and more households incorporate flowers into their daily lives. The many possibilities hidden within this simple flower sleeve will play a key role in realizing that vision.

Impack is a leading company in the Japanese flower industry.

Scope of Business

Impack's domain is "M&S+R"

Impack's Domain lies on "M&S+R"

M : Machine

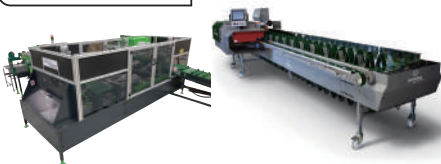

S : Sleeve (Flower bag)



R : Retail Support

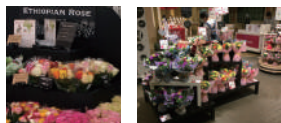

バイオマス  
使用部位：フィルム  
No.200176



バイオマス  
使用部位：インキ  
No.160016

Biomass  
mark



We are committed to  
environmental protection

Go green

With Machine, Sleeve and Retail support, we create a way of life that brings flowers closer to you. Paper Sleeves and Biomass Sleeves wrap flowers naturally and are environmentally friendly!

The latest computer-controlled, streamlined, labor-saving unit.

# Flora Optima

Discover the video on YouTube.



Production capacity  
**Up to 4000 bundles/hour**

**Flower catching mats** at the end of the production line to receive bouquets



Easy operation on the **touch-screen**



**Press-on-belt** prevents bouquets from shifting during cutting and leaf stripping.



Clean cut!

**Sponge wheels and Triangle Belt** reduce bouquet misalignment



**Length adjustment plate** to help adjust bouquet length



The CRM binder is the latest model that does not produce much rubber dregs. Easy to clean and will not damage flowers.



Having a **spare knot tying device** ensures timely repairs in the event of a machine breakdown.

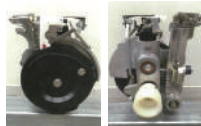

**The deleafing unit** removes up to 29cm of leaves from the stem. The de-leafing brush is available in two different rubber hardnesses to accommodate a wide variety of flowers.

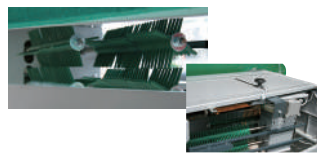

A special blade is used to cut the flowers without damaging the conduit, so the flowers will last longer.



A round cutter

Top and bottom 2 round cutters



Machine length 5-20mm

**We customize machine specifications for "cutting", "deleafing" and "binding" to suit your work and working environment. We also propose linkage and expansion with other modules such as sleeving machines, automatic labeling machines, and conveyor belts.**

[Specification]

- Product code: 520556
- Size: 5 to 20 meters long
- Power supply: 3-phase 200V, 50/60Hz
- Conveyor width: 800mm
- Conveyor height: 800-1000mm
- Completely custom-designed to order. Designed with safety in mind, including an emergency stop switch for emergency stop and a cover to prevent cutter injury. Delivery time is approximately 10 months.

State-of-the-Art Concept Control. The latest computer-controlled, streamlined, labor-saving unit.

# Flora Optima Preprocessing

**The deleafing unit** removes up to 29cm of leaves from the stem. The de-leafing brush is available in two different rubber hardnesses to accommodate a wide variety of flowers.

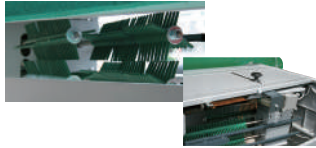

**Replacement brushes**

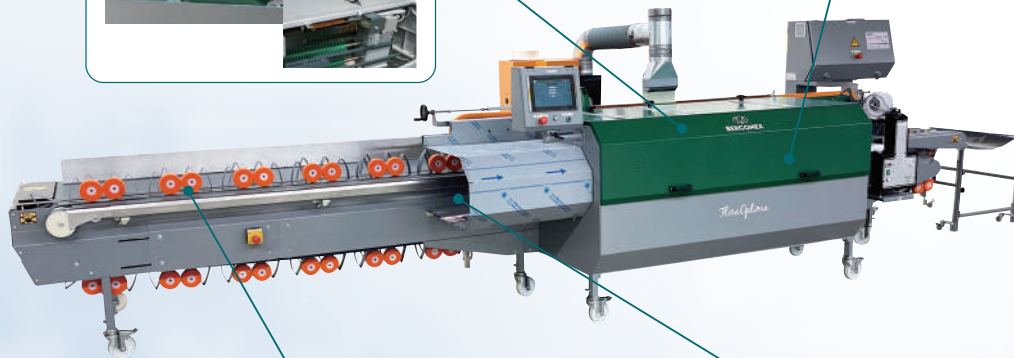

**Sponge Wheel, Triangle Belt**



A special blade is used to cut the flowers without damaging the conduit, so the flowers will last longer.



A round cutter

Top and bottom 2 round cutters



**Processing capacity: up to 4000 bundles/hour**  
**Greatly reduces the burden of dealing with leaves and thorns!**  
**Work efficiently with fewer people**

- Flora Optima is designed for cutting flowers and removing lower leaves.
- Can be cut into lengths of about 40cm to 120cm.
- Optionally, one or two deleafing unit(s) are available. Equipped with two devices for added convenience! Capable of removing leaves up to 29 cm long  
\*You can choose between hard and soft brushes depending on the flower material.
- Recommended for large chrysanthemums, small chrysanthemums, roses, and more.
- The shortest machine length is about 4.5 meters.
- By installing the CRM binder machine, it can also be used as a production line in case of emergency.

**We will advise you on the layout of your workshop. We will help you create a better working environment.**



# Automatic Sleeving Machine

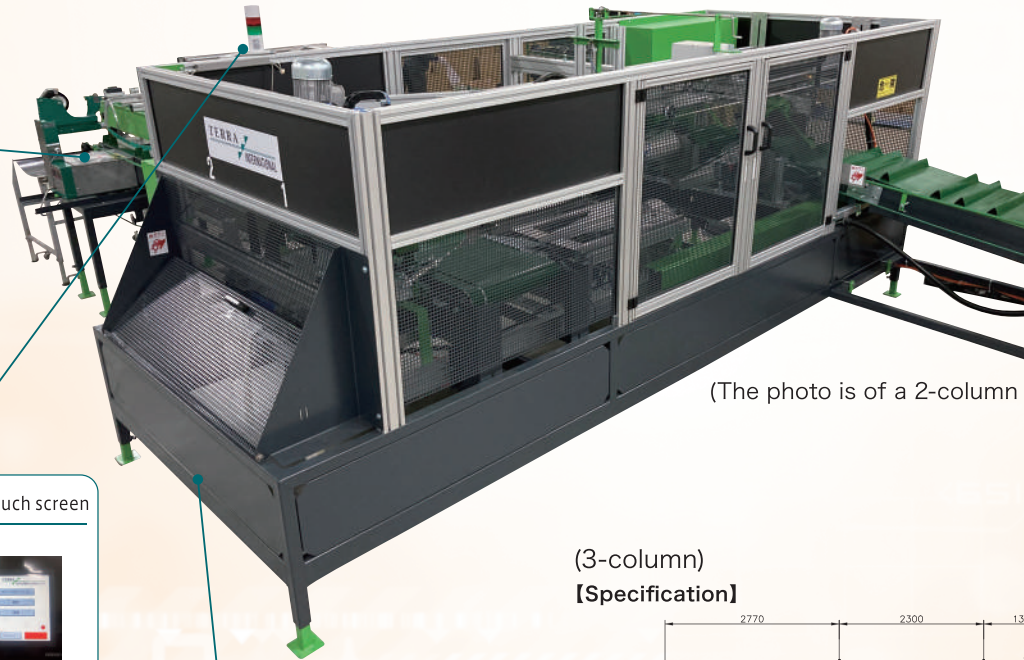

(The photo is of a 2-column type)

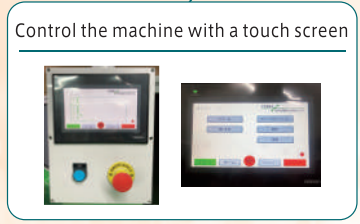

**Maximum of 50 sheets x 7 bundles can be set**  
\* Requires the use of specially sized flower covers. Can be safely refilled even with the machine running.

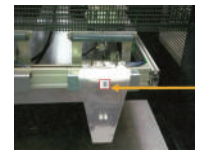

(3-column)  
【Specification】

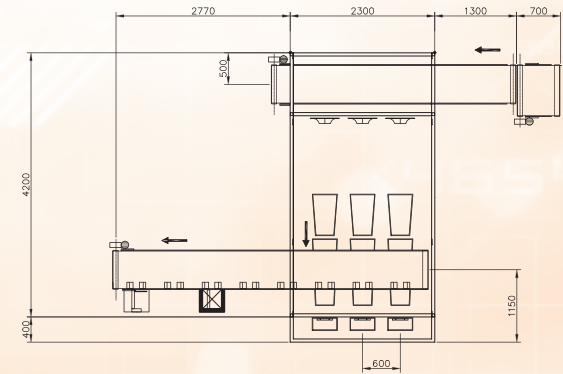

Production capacity  
**Up to 3500 bundles/hour**

3-column

Production capacity  
**Up to 2300 bundles/hour**

2-column

- **Automatic flower bagging machine**  
Works in conjunction with Flora Optima. Fully automated flower bagging.
- **For all types of bouquets**
- **Height can be customized**  
Can be linked with other machines such as automatic labeling machines and conveyor belts.

\*Separate air compressor required.



Automatic sleeving machine	
Size	6470×4600(mm)(2-column type) 7070×4600(mm)(3-column type)
Power supply/power	3-phase 200V/50,60Hz
Product code	500020



Connect with the Optima and Automatic Sleeve Machine for even greater convenience

Discover the video on YouTube.

# Automatic Flower Labeling Machine AP-800



Label Specifications:  
Width 40-80mm  
Length 28-100mm

If spare tapes are purchased separately, replacement can be accomplished without problems



Touch screen control, easy to operate



Maximum workload  
**66.7 cycles/minute**

## Increased efficiency

- Reduced labeling labor, workload and work hours
- Easy to create labels and to manage data
- Format management ⇒ Create label designs on your computer
- Database management ⇒ Input characters to print on the computer
- History Management ⇒ You can manage the history of the label releases
- Separate compressor required

### 【Specifications】

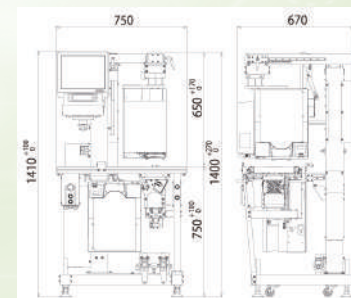

### Automatic labeling machine AP-800

Size	750×670×1400H(mm)
Printing method	Thermal print
Label size	Width 40-80mm, length 28-100mm
Power Supply/Power	AC100V/185-340w
Code	515093

For creating a comfortable working environment

# Dust Collector

SDC-750CS3-5/6

Discover the video on YouTube.



Powerful suction and high performance filters

## Keep the air fresh

- With a central exhaust port that can be connected to an exhaust pipe
- Clean duct design
- Intake ports face up and can be installed in up to 4 positions

[an actual example]



[Specification]

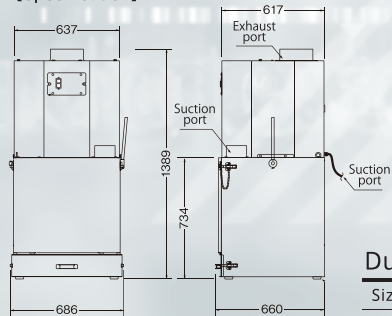

Dust Collector SDC-750CS3 -5/6

Size/Weight	686×660×1389H(mm)/111kg
Power supply/power	3-phase 200V/0.75kw
Product code	516014 (50Hz)
Product code	516026 (60Hz)



Water Filling Automation

# Flower Bucket Water Filling machine Aquamatic

Discover the video on YouTube.



processing capability  
**700 buckets/hour**

\*Quantity varies with water pressure

①The buckets are stacked together and the buckets then automatically fall one by one onto the conveyor belt and are filled with water.

Optionally, a freshness diluter can be installed.

The air-blowing mechanism makes separating the buckets much easier.  
\*A separate air compressor required

conveyor belt type  
**Flower Bucket Water Filling machine**

②When the flower bucket reaches the edge of the conveyor belt, it stops automatically with a sensor.

Water supply can be adjustable.

③When the bucket on the conveyor belt is finished being picked up, it automatically fills the next bucket with water and sends it out.

Stacked buckets automatically fall onto the conveyor belt in sequence. It doesn't take long to remove buckets that are stuck together, and your hands don't get sore from it.

[Specification]

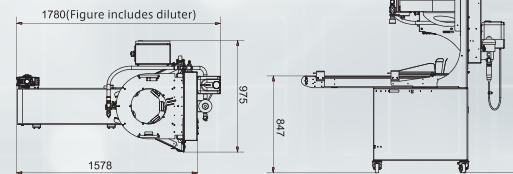

\*Supported Bucket Sizes  
Φ160~310 x H150~355mm  
\*Additional hose connection required

Flower Bucket Water Filling machine  
**Aquamatic**

Dimensions/weight	1570×975×H1700mm (conveyor belt length 1.25m)/approx. 180kg
Power supply	3-phase 200V
Code	502005



# Tabarin ARC



Specialized elastic cords are used for strapping machines

## There is no need to use tape or rubber bands!

**Production capacity**  
**Up to 80 bundles/min**

- Use special elastic cord to avoid damage to flower stems
  - 1 roll of elastic rope can be tied 5000-7000 times
  - 3 colors to choose from
- Easy to manage by using different colors according to the processing day

**Specialized Consumables**

Elastic rope for strapping machines T-S  
12 rolls/box

Color	Code
White	522031
Yellow	522032
Green	522033



- The strength of the knot can be adjusted with a rubber tensioner.
  - Applicable to a wide range of floral materials by adjusting the knotting.
- 

- Hand-push switch to tie flowers
  - Less than 1 second to tie
  - No damage to hands and fingers
- 

Equipped with casters for easy movement

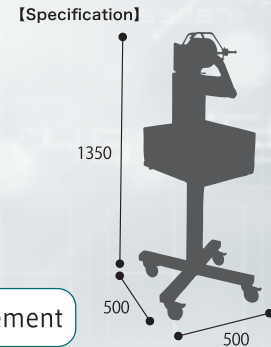

**Tabarin ARC**

Size/Weight	500×500×1350H(mm), approx.45kg
Power supply/power	100V/0.2kw
Product Code	501101



Deleafing machine

# Hatore S-40

Discover the video on YouTube.



## Rubber brushes remove leaves immediately

<b>Production capacity</b> 10 chrysanthemums	<b>Processing time</b> 5 seconds/time	<b>Quantity handled</b> 7200 branches/hour
---	--	---



- The brush rotation speed can be changed with the control switch.



[Specification]

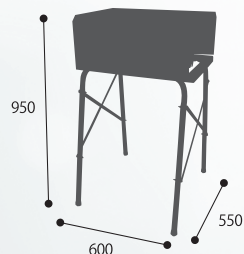

Hatore S-40型

Size/Weight 550×600×950H(mm)/Approx.27kg

Power supply/power 100V/0.4kw

Code 505005

- Easy brush replacement
- Quiet sound during operation
- Using both soft and stiff brushes, you can remove the lower leaves of most flowers (chrysanthemums, roses, etc.)

Brushes can be used both top and bottom without waste.

### Specialized Consumables

#### Hatore Brush



SH-2 (hard, 1 set of 2)  
Code : 520886



SS-1 (soft, 1 set of 2)  
Code : 520900

Flower cutter

# Cutting machine for flowers

Discover the video on YouTube.



<b>Production capacity</b> 20 chrysanthemums/time	<b>Processing time</b> 5 seconds/return (from placement to cutting)	<b>Quantity handled</b> 14,000 chrysanthemums/hour
--	---	---

Simply place the flowers and push the tray !

## Labor-saving high-volume processing

- It comes with a scale so you can see the length at a glance.



- Ideal for handling large quantities of products
- Built-in brake motor for safe operation
- Designed at an easy-to-operate height, ensuring safety, security, and reducing fatigue

[Specification]

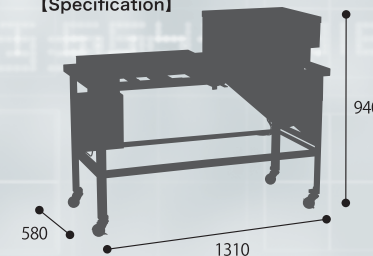

### Cutting machine for flowers

Size/Weight 1310×580×1056H(mm)/Approx. 50kg

Power supply/power 3-phase 200V/0.75kw

Code 503001

Flower Bucket Cleaner

Discover the video on YouTube.

# Goshigoshi IP500



Cleaning of the flower buckets is the basis for controlling freshness.

Processing capacity  
Up to 700 buckets/hour

## Automatic cleaning of flower buckets

- Processing time : 5 to 10 seconds per bucket.
- Thorough cleaning with water in a short period of time
- Clean the inside and outside of the bucket with 3 brushes!
- Available for round and square drums.

### Washable Bucket Size

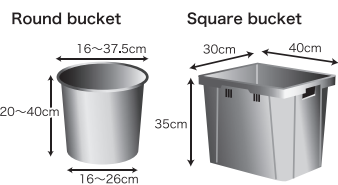

The above mentioned size is only one example. Multiple sizes can be used



### [Specification]

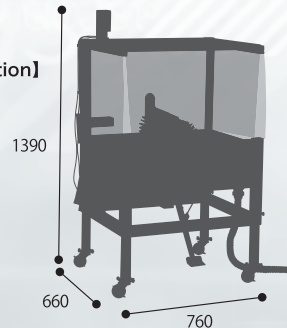

### Goshigoshi IP500

Size/Weight	760×660×1390H(mm)/40kg
Power supply/power	100V/0.3kw
Code	511005 (50Hz)
Code	511006 (60Hz)

Flower Sleeve Stand

# PS-DS PS-DB

## Wrapping bouquets is three times faster than manual work!

### ■ Easy to install flower sleeves

Open the head of the sleeve stand and set the sleeves.



- Height adjustable
- Can be packaged in parallel with FloraOptima
- This product is assembled by the customer



Flower Sleeve Stand PS-DS  
Code 504002

Flower Sleeve Stand PS-DB  
Code 504001

### [Specifications] customer-assembled product

Hood size (diagram from above)

DS(small)

DB(large)

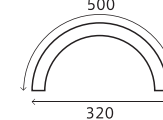
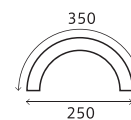

Small sizes (DS) are available for standard flower sleeves (top width max. 400 mm)

### ■ Usage

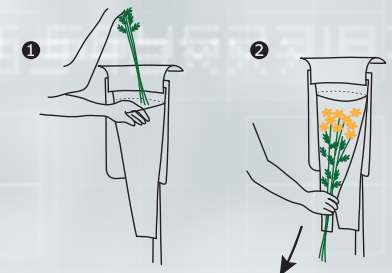



Flower bouquet water packaging machine

# Mini bouquet Rond

Discover the video on YouTube.



Spiral Bouquet Machine

# Hand-tied bouquet machine

Discover the video on YouTube.



## Packing with water supply

- Securely fastened with a rubber band, it can be quickly wrapped with just a ribbon or other embellishment.
- Adjustable water supply
- A freshness thinner can also be added.

### Specialized Consumables



Easybul 70 Easybul 110 Easybul 130

Pinch the stem and tighten with parts to secure.

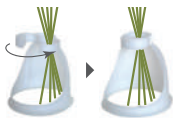

Specialized Rubber Bands Natural Brown

Processing capacity  
Up to 120 units/hour



### Specialized rubber bands natural brown [Specification]

Size(mm)	Code
50×12	151211
Retail Price	Shipping Unit
10,000yen	1kg(about 700 pieces)

### Easybul

Size(mm)	Code	Retail Price	Shipping Unit
Easybul 70 φ110×70H	467112	253円	100個
Easybul 110 φ110×110H	467113	276円	
Easybul 130 φ130×130H	467114	403円	

### Mini Bouquet Rond \*Compressor required for use.

Size/Weight	600×720×1150H(mm)/Approx. 62kg
Power supply/power	100V/0.03kw
Code	467117

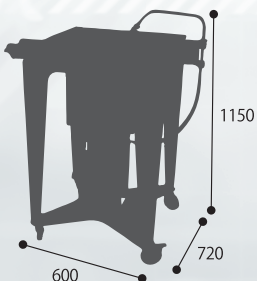

## spiral bouquet mass produce

Processing capacity  
550 units/hour  
(Based on a bouquet of 24 flowers and 12 staff members)

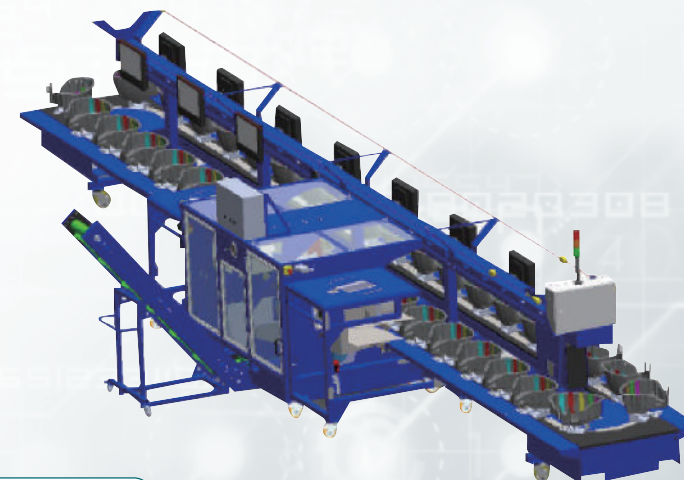

- Just place flowers on the production line! Bundle, Tie, cut, and automatically complete the spiral bouquet !
- Anyone can easily create spiral bouquets by following the on-screen instructions for placing flowers.

\*An additional compressor is required

### [Specification]

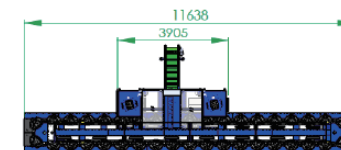
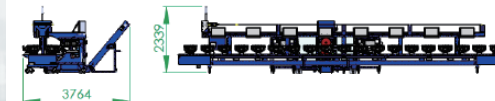

### Hand-tied bouquet machine

Size/Weight	11.7×3.8×2.34H(m)/2574kg
Power supply/power	3-phase 200V/2.5kw



# Automatic Chrysanthemum Flower Selection and Bundling Machine

## MZH-4000S-TB4

rubber band binding

Discover the video on YouTube.



## Automatic grading of chrysanthemums

Flower-head alignment, cut, Deleafing, grading and Tying are all automatic.

Processing capacity  
**Up to 4000 branches/hour**

Number of grades 5 grades

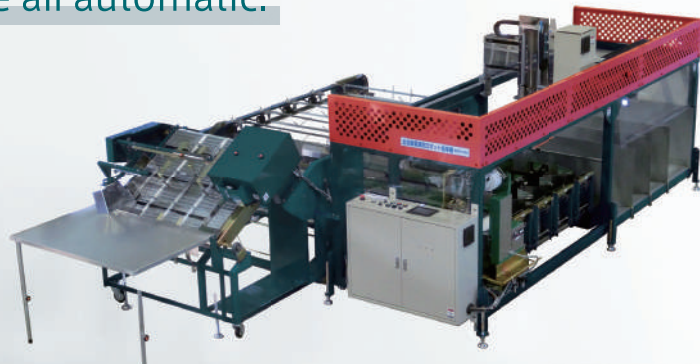

- Applicable to large chrysanthemums, small chrysanthemums (70-90cm)
- Flower heads are aligned neatly
- Excluding shorter-than-standard chrysanthemums to avoid defective products
- Deleafing box is easy to open for easy cleaning
- Customization available upon request

### Specialized Consumables

Elastic rope for strapping machines T-S  
12 rolls/box



Color	Code
White	522031
Yellow	522032
Green	522033

### MZH-4000S-TB4 Rubber Bands Strapping

Size/Weight 5650×2690+280mm/1300kg

Power supply/power 3-phase 200V/4kw

Code 516008

### 【Specification】

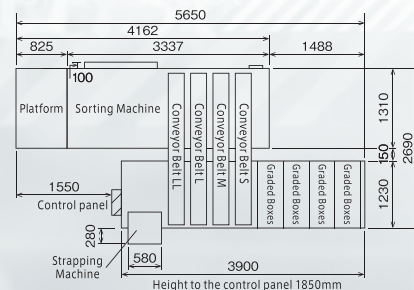

## labeling machine

# Pot labeler

LA-5M-SCH-CK

Discover the video on YouTube.



# Seedlings, potted flowers Label cross-laminator

Processing capacity  
**Up to 80 sheets/minute**  
(depending on workpiece)

Number of registered varieties: 100 varieties

Label specifications: width 25-60mm,  
length 15-200mm

- 7-inch wide-format color LCD touch screen for improved visibility and operability



### 【Specification】

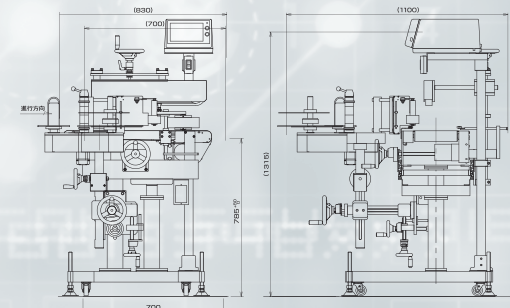

### Pot labeler LA-5M-SCH-CK

Size/Weight 830×1,100×1,315H(mm)/Approx. 150kg

Power Supply/ Power AC100V ± 10% 50 / 60Hz  
500W max